

Manual Rockwell Hardness Testing Machine

Vexus SHR-150M

Operation Manual



Cautions

1. Read carefully the Instruction Manual before operating the present instrument in order to know the operational procedures and the cautions for the usage so that the damages and the safety accidents caused by the incorrect operations may be avoided.
2. Strip off the packing Belts and the Anti-shock Adhesive Tapes Carefully When the Instrument is Installed and Tried.
3. During the loading and unloading as well as the dwell time of the test force, don't rotate the carriage-changing hand-wheel on the rotary wheel.
4. Our company makes every effort to improve the quality of the hardness tester and hence changes the structure from time to time. In case the contents of the Instruction Manual is a bit not in conformity with the structure of the instrument, there would not any further notice to be given, for which we would like to beg your pardon.

Contents

1. A Brief Introduction to the Hardness Tester
2. The Technical Parameters of the Hardness Tester
3. Rockwell Hardness Test Scale, Indenter, Test Force and the Usage Field
4. The Installation of the Hardness Tester
5. The Correct Usage of the Hardness Tester
6. The Maintenance and the Cautions of the Hardness Tester
7. The Accessories (the Packing List)

I A Brief Introduction to the Hardness Tester

1.1 The hardness is one of the important criteria of the mechanical functions of the materials, and the hardness test is the important means to judge the quality of the metallic materials or parts, As the metallic hardness has mutual correspondent relations with other mechanical functions, the majority of the metallic materials can calculate the other mechanical functions such as the strength, the fatigue, the evolutionary change and the degree of being worn out can be approximately inferred from the hardness shown by the test.

1.2 The manual Rockwell hardness tester is a popularly-used hardness testing instrument to measure the Rockwell hardness of the materials. The speed of loading the test force is regulated by the buffer whereas the change of the test force is made by rotating the carriage-changing hand-wheel. The operation of the present instrument is simple, its functions are stable, and its use is, therefore, widely spread.

II Technical Parameters of the Hardness Tester

2.1 The initial test force: 98.07N(10kg), the allowed tolerance: $\pm 2.0\%$

2.2 The Total Test force: 588.4N(60kg), 980.7N(100kg), 1471N(150kg), the allowed tolerance: $\pm 1.0\%$

2.3 The specifications of the indenter:

2.3.1 Diamond Rockwell indenters

2.3.2 Ball indenters $\phi 1.5875\text{mm}$

2.4 The max height of the specimens: 175mm

2.5 The distance from the center of the indenter to the instrument body: 165mm

2.6 The total dimension of the tester(length x width x height) : 520 x 215 x 700 (mm)

2.7 The total weight of the tester: 100kg.

2.8 The allowed tolerances of the indicated values of the hardness tester (Table I)

Table I

Hardness Scale	Hardness Range of the Standard Blocks	Max Tolerance of the Indicated Values
HRA	(20~75)HRA	±2HRA
	(>75~88)HRA	±1.5HRA
HRB	(20~45)HRB	±4HRB
	(>45~80)HRB	±3HRB
	(>80~100)HRB	±2HRB
HRC	(20~70)HRC	±1.5HRC
HRD	(40~70)HRD	±2HRD
	(>70~77)HRD	±1.5HRD
HRE	(70~90)HRE	±2.5HRE
	(>90~100)HRE	±2HRE
HRF	(60~90)HRF	±3HRF
	(>90~100)HRF	±2HRF
HRG	(30~50)HRG	±6HRG
	(>50~75)HRG	±4.5HRG
	(>75~94)HRG	±3HRG
HRH	(80~100)HRH	±2HRH
HRK	(40~60)HRK	±4HRK
	(>60~80)HRK	±3HRK
	(>80~100)HRK	±2HRK

III Scale, Indenter, Test Force and Application Field of the Rockwell Test (Table 2)

Table 2

Scale	Type of Indenter	Initial Test Force	Total Test Force (N)	Application Field
HRA	Diamond indenter	98.07 N (10kg)	588.4 (60kg)	Hard Alloys, Tempered steel with carbonized surface, Hardened Steel Plates
HRD			980.7 (100kg)	Thin steel plates, steel with tempered surface
HRC			1471 (150kg)	Quenched steel, tempered steel, hard cast iron
HRF	Ball indenter φ 1.5875m (1/16inches)		588.4 (60kg)	Cast iron, aluminum-magnesium alloy, bearing alloy, annealed copper alloy, thin and soft steel plate
HRB			980.7 (100kg)	Soft steel, aluminum alloy, copper alloy, forgeable cast iron, annealed steel
HRG			1471 (150kg)	Phosphorus bronze, beryllium bronze, forgeable cast iron
HRH	Ball indenter φ 3.175mm (1/8 inches)		588.4 (60kg)	Aluminum, Zinc, Lead
HRE			980.7 (100kg)	Bearing alloy, tin, hard plastic materials
HRK			1471 (150kg)	

There are 3 Rockwell Hardness Test Scales: Scale A, Scale B and Scale C.

IV Installation of the Hardness Tester

The working conditions of the hardness tester

Within the room temperature of 10-30°C;

In the room relative humidity non superior a 65%;

In un surrounding without any shock or corrosive medium;

The unpacking of the hardness tester

Cut off the packing belts on the eternal box and unscrew out the screws on the bottom edges of the wooden box and then take off the cover and take out the accessories kit.

Unscrew with a spanner the 2 outer hexangular bolts M10 to separate the tester from the base place (pay attention to the safety).

Place the tester horizontally and steadily on the working table with the horizontality non superior a 1mm/m. while open a hole in the working table (Fig.1) so as to allow the operating lever (6) to move normally. The suggested height of the table is about 500mm.

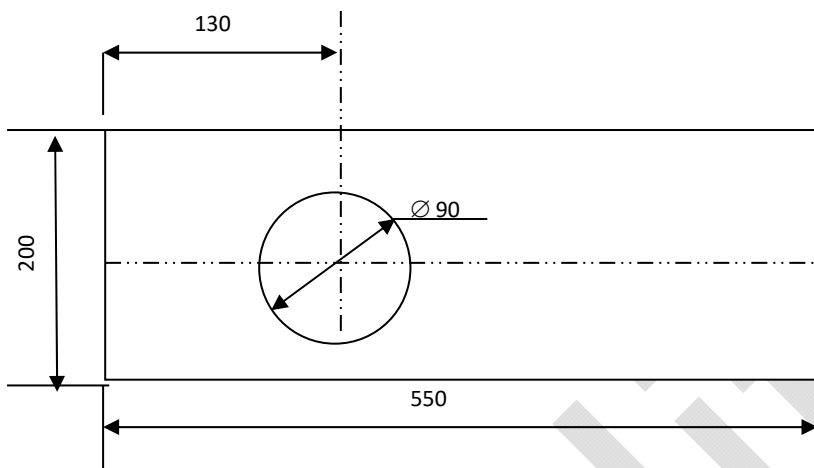

Fig. 1

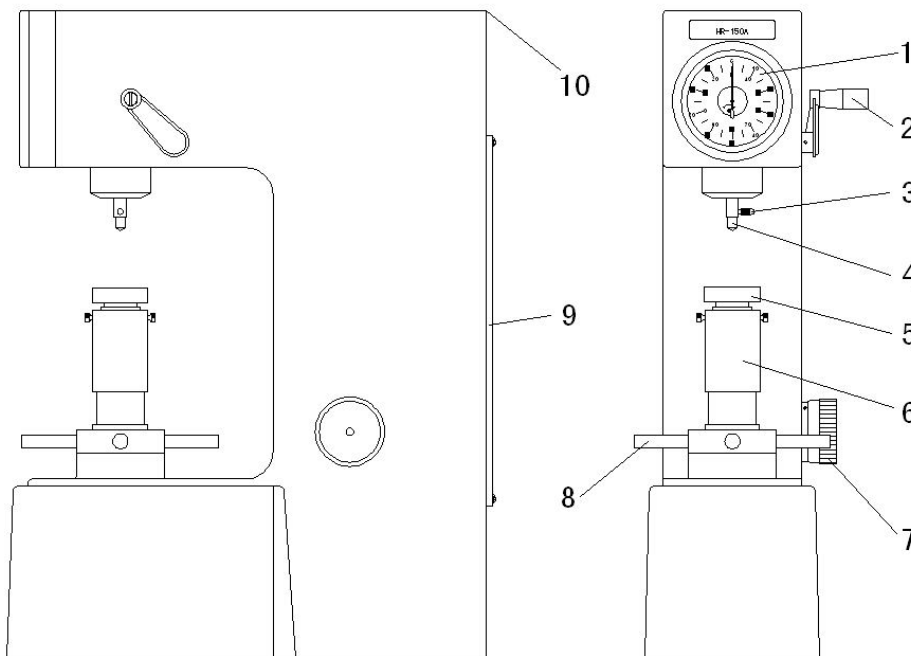

Fig.2

1. Dial; 2.Handle for loading and unloading; 3.Fixing Screw for Indenter; 4.Indenter;
- 5.Testing Table; 6.Operating Lever; 7.Hand wheat for Changing the Carriage; 8.Rotary wheel; 9.Back cover; 10.Upper cover

4.3 Installation of the Hardness Tester (Fig. 2)

When the hardness tester is well placed, open the upper cover (10) and the back cover. Unfasten the rubber belt locking the shaft (22) in the instrument body (Fig.6) and draw out the protective spacer (25) and the foamed plastic block under the level (11). And then unfasten off all the cotton belts fixing the movable parts and finally put on the cover to prevent the dust from entering the instrument.

4.4 Installation of the set of Weights

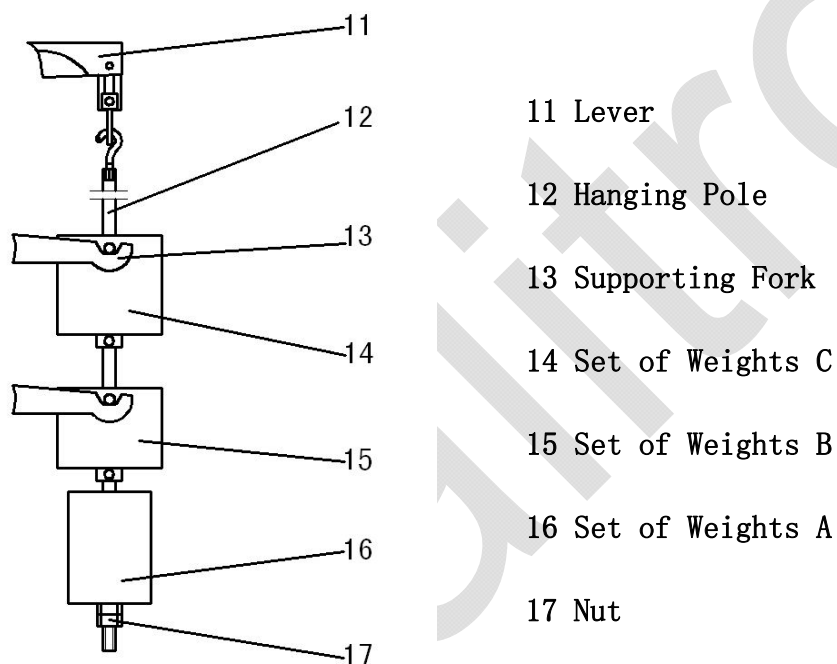

- 11 Lever
- 12 Hanging Pole
- 13 Supporting Fork
- 14 Set of Weights C
- 15 Set of Weights B
- 16 Set of Weights A
- 17 Nut

4.5 At the to install the weights, the carriage-loading and unloading handle (2) should be in the front position and the instrument should be in the state of absent carriage.

4.6 Take out the sets of weights from the accessories kit and rub them clean. Rotate the carriage-changing hand wheel (7) to the point of 588.4, and take out the hanging lever (12) from the back cover and insert the set of weights (16) into the hole, and the screw tight the nut (17) and hook the hanging pole into the hole at the end of the lever. Place the set of weights B (15) and the set of weights C (14) on the two supporting forks (13) and then rotate the carriage-changing hand-wheel to

complete a circle and observe whether the round pins on the two sides of the weight are

well placed into the grooves on the supporting hook. The weights should be in the center, and so they should be kept away from any component part on the inner surface of the instrument body (and therefore the horizontal level should be carefully adjusted.)

4.7 Select the correspondent relations between the test force and the weights (Table 3)

Table 3

Scale	Test Force (N)	Graduated value on the carriage-changing hand-wheel	Force Received by the weight (code of the weight)
HRA	588.4 (60kg)	588.4 (60)	Hanging pole + set of weights A
HRB	980.7 (100kg)	980.7 (100)	Hanging pole + set of weights A + set of weights B
HRC	1471 (150kg)	1471 (150)	Hanging pole + set of weights A + set of weights B + set of weights C

4.8 Method of furnish oil into the oil container (Fig 4)

When the hardness tester is turned out of the factory, the oil in the container is filled with oil. If there occurs a leakage during the transport, the client should prepare a bout 20 milliliters of machine oil and put it in the container by himself.

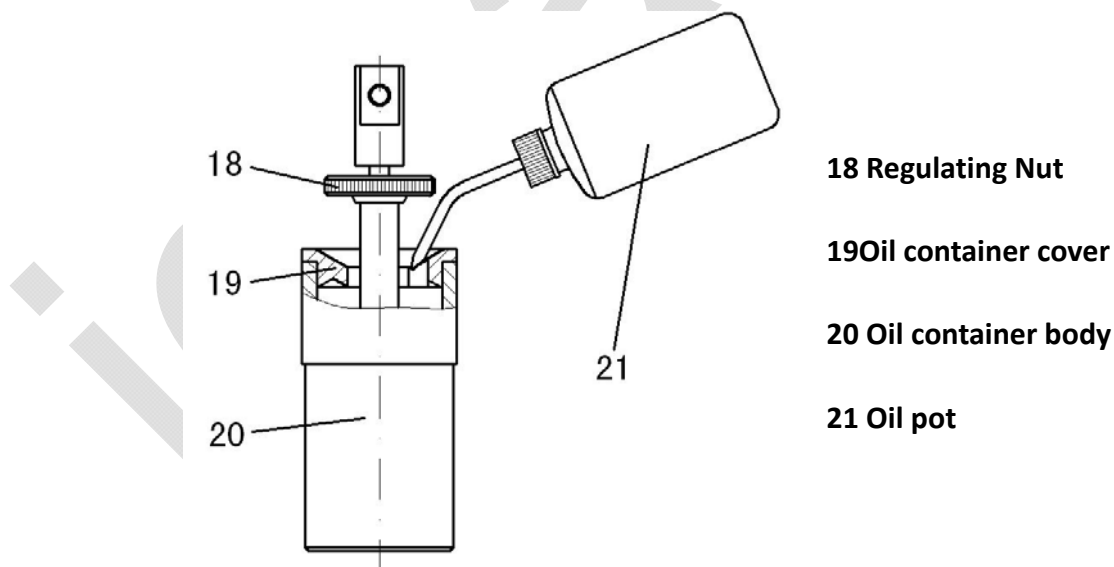

Fig 4

The method: Take off the upper cover and push the carriage-loading and unloading handle backward and the use the oil pot (21) to pour the oil into the hole in the container cover (19). The volume of the oil added depends on the handle movement to

pour the oil until then handle moves without any noise of inhaling the air. Too much oil poured would overflow out.

4.9 Adjust the speed of loading the test force after installing the indenter (4) place the HRC block with a low hardness on the testing table (5), and rotate the rotary wheel clockwise to lift up the testing table, when the hardness block touches the indenter, the hands on the dial begin to move around. When the big hand complete 3 circles, stop rotating the rotary wheel, and push backward the carriage-loading and unloading handle to observe the rotating speed of the dial hands. The time range from when the hands begin to move around to when they stop moving covers 2-6 seconds. You may rotate the regulating nut (18) on the container body to determine the high speed or the low speed of loading the carriage. To rotate the nut clockwise makes a high speed while to rotate it otherwise reduces the speed. Below there is a reference table showing the speeds of the loading time, the dwell time and the unloading time of the test force (table 4).

Table 4

Loading Time	Dwell Time	Unloading Time
2~6 seconds	5 seconds	2~3 seconds

V Correct Operation of the Hardness Tester

5.1 The preparatory works before the operation

5.1.1 Make sure that the surface of the specimen should be smooth and clean without any dirt, oxidized layer, sunken spot or processing trace. The supporting surface of the specimen and the plane of the testing table should be clean in order to have an intimate touch.

5.1.2 The min. thickness of the specimen should be more than 10 times greater than the depth of the indentation. After the test, there should be not visible deformed traces on the back of the specimen. For the relation between the min. thickness of the specimen and the hardness. See Fig. 5.

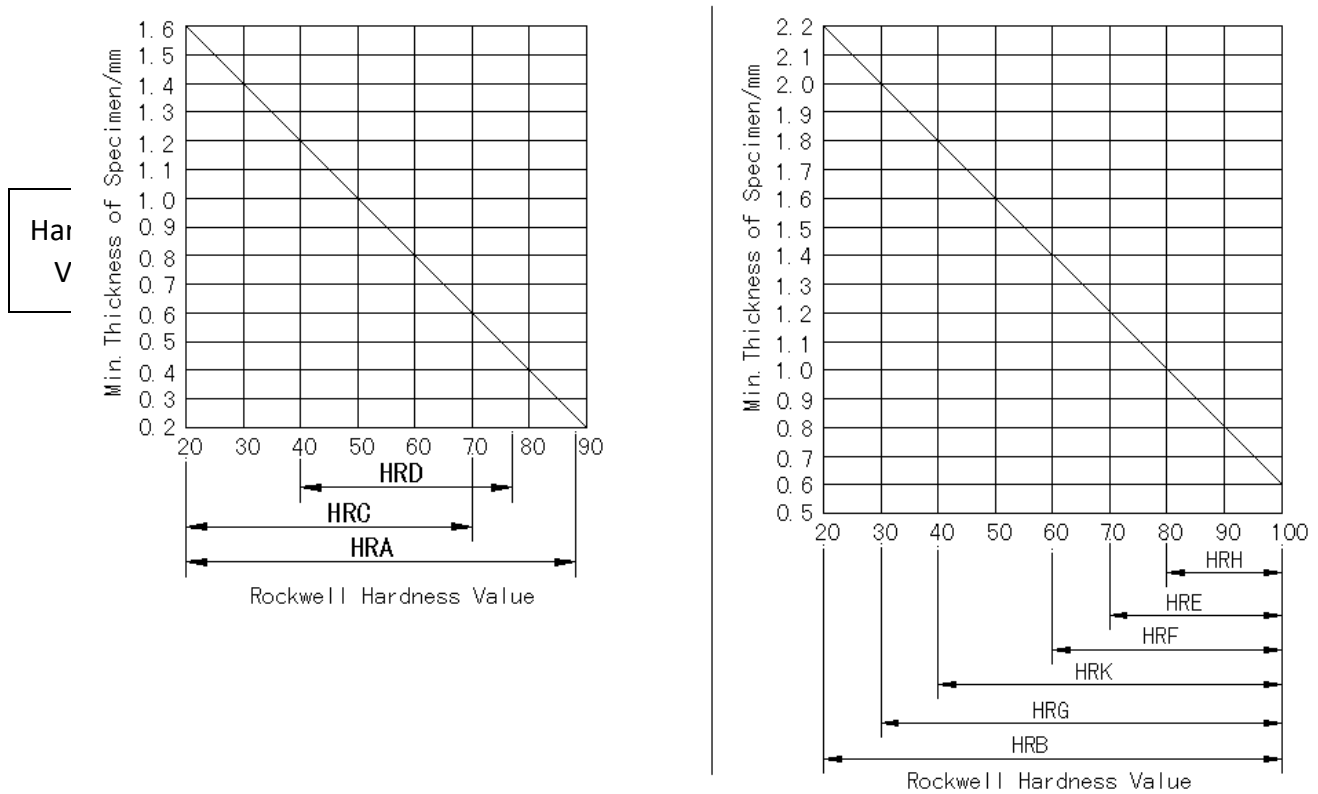
Fig. 5

5.1.3 The specimen should be steadily placed on the testing table and should not be slightly moved during the operation of loading and unloading the test force so as to assure that the test force falls on the specimen vertically.

5.1.4 Choose the suitable testing table according to the shape and dimension of the specimen. If the specimen has an irregular shape, it is necessary to make by our selves the fixture according to its actual geometrical shape in order to obtain a reliable hardness value.

5.1.5 In case the specimen is a cylinder in shape, it is necessary to use the V-shaped testing table. When the diameter of the specimen is less than 38(25) mm, its testing result should be readjusted. The adjusted values are generally positive figures (Table 5).

Table 5

HR	Adjusted Value (HR) by Rockwell Scales A. C. D.								
20				2.5	2.0	1.5	1.5	1.0	1.0
25			3.0	2.5	2.0	1.5	1.0	1.0	1.0
30			2.5	2.0	1.5	1.5	1.0	1.0	0.5
35		3.0	2.0	1.5	1.5	1.0	1.0	0.5	0.5
40		2.5	2.0	1.5	1.0	1.0	1.0	0.5	0.5
45	3.0	2.0	1.5	1.0	1.0	1.0	0.5	0.5	0.5
50	2.5	2.0	1.5	1.0	1.0	0.5	0.5	0.5	0.5
55	2.0	1.5	1.0	1.0	0.5	0.5	0.5	0.5	0
60	1.5	1.0	1.0	0.5	0.5	0.5	0.5	0	0
65	1.5	1.0	1.0	0.5	0.5	0.5	0.5	0	0
70	1.0	1.0	0.5	0.5	0.5	0.5	0.5	0	0
75	1.0	0.5	0.5	0.5	0.5	0.5	0	0	0
80	0.5	0.5	0.5	0.5	0.5	0	0	0	0
85	0.5	0.5	0.5	0	0	0	0	0	0
90	0.5	0	0	0	0	0	0	0	0
Hardness Value (HR)	Diameter of the Cylindrical Specimen (mm)								
	6	10	13	16	19	22	25		
	Adjusted Value (HR) by Rockwell Scales B. F. G.								
20					4.5	4.0	3.5	3.0	
30				5.0	4.5	3.5	3.0	2.5	
40				4.5	4.0	3.0	2.5	2.5	
50				4.0	3.5	3.0	2.5	2.0	
60		5.0		3.5	3.0	2.5	2.0	2.0	
70		4.0		3.0	2.5	2.0	2.0	1.5	
80	5.0	3.5		2.5	2.0	1.5	1.5	1.5	
90	4.0	3.0		2.0	1.5	1.5	1.5	1.0	
100	3.5	2.5		1.5	1.5	1.0	1.0	0.5	

5.2 Operational Procedure of the Hardness Tester

5.2.1 In order to choose the scale (Table 2) according to the softness and hardness of the specimen, rotate the carriage-changing hand-wheel to determine the total test force. All the changes of the test force should make the instrument stay in the state with all the test forces unloaded. (The loading and unloading handle stays in the front position)

5.2.2 Put on the indenter with the notch of the indenter handle facing the screw; tighten

slightly the fixing screw (3), and then place the specimen on the testing table.

- 5.2.3 Rotate the rotary wheel to lift up the lever so that the specimen may move solely to touch the indenter without any shock until the little hand of the comparator moves to the red point from the black point meanwhile the long hand points at the spot "C" after three cycles. The deviation of the long hand should not surpass 5 graduated Value. If the deviation has surpassed this limit, one should not make it move back. It is necessary to lower the lever and re-select the position of the testing point (When the HRB hardness is tested the long hand should point at "B"). At this time, the initial test force of 98.07N (10kg) is loaded. Rotate the dial to let the hand point at "C".
- 5.2.4 Push the handle back slowly and make sure that the test force is loaded within 2-6 seconds. The dwell time of the test force is seconds. And then pull the handle forward steadily within 2-3 seconds to unload the main test force but keep the initial test force.
- 5.2.5 At this time, the figure at which the long hand of the comparator points is the hardness of the specimen. (When the HRB hardness is tested, its value should be read in the inner cycle.)
- 5.2.6 Rotate the rotary wheel backward to lower the testing table. Change the testing point and repeat the above-described operation.
- 5.2.7 No less than 5 testing points should be chosen for the specimen (the first point is not counted.) For the test of a great number of specimen, the number of the testing points could be rationally reduced.



When you load unload the test force, it is prohibited to rotate the carriage-changing hand wheel. The forcible rotation would shift the position of the component parts and make errors and mixtures in the test forces.

5.3 Adjustment of the Indicated Hardness Values (Fig. 6)

The precision of the Value indication of the hardness tester is calibrated before it is turned out of the factory. If there occur some errors due to transportation, the testing operators could make certain adjustments on the base of knowing the structural principles of the instrument. The method is as follows: After taking off the upper cover, if they find the indicated value of the test is lower than that of the standard block, they should loosen the nut M4 (23) and rotate the screw (24) clockwise slowly and make zero on the dial, and then fasten the nut to test the indicated value again until it is adjusted into the tolerance range (Table 1). If the indicated value of the test is higher than the standard hardness, rotate the screw backward.

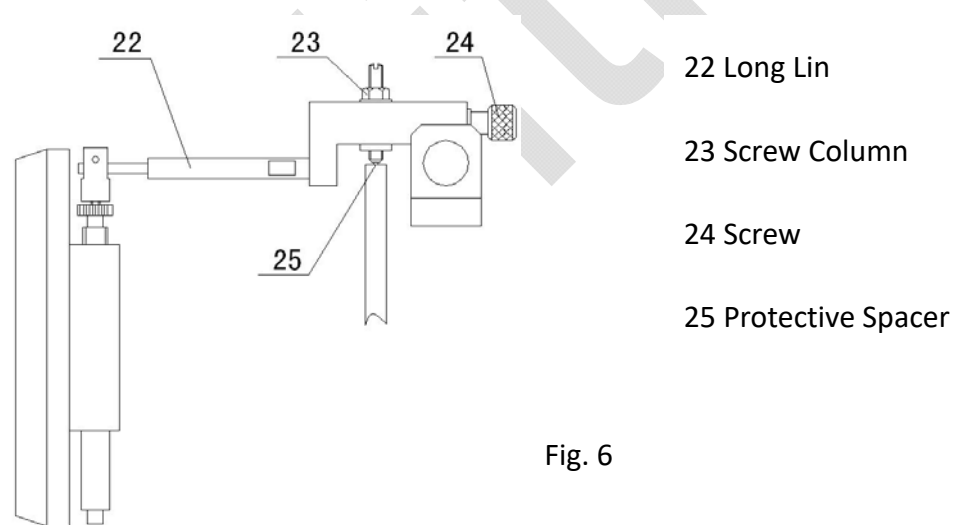

Fig. 6

VI Maintenance and Attentions of the Hardness Tester

6.1 The testing operators should observe the rules of operations and be able to calibrate the instrument with the standard blocks before the test. If the instrument is not often used, after the instrument is started, they should make several tests with the blocks. Once the instrument is stable, it is time to carry out the hardness test.

6.2 If the instrument needs to be moved, the tester should be vertical during the transportation. It is prohibited to carry the instrument horizontally. Meanwhile the

weights and the hanging lever should be dismantled during the transportation.

6.3 At the loading, unloading and dwell time of the test force during the testing, It is prohibited to rotate the carriage-changing hand wheel.

6.4 The standard blocks are used only on the working surface. The distance between two neighbor indentations and that of the indentation centre to its edge should not be less than 3 mm. Their usage cycle is two years,

6.5 Fixing of the Ordinary Breakdowns of the Hardness Tester

When the tester has broken down or is out of order, it is necessary to communicate with the unit concerned for the repair. The ordinary breakdowns can be solved by the operators themselves. (Table 6)

Phenomena	Possible Cause	Methods for troubleshooting
The long hand of the dial is deviated and does not point at the zero	The adjustment of the indicated hardness value may cause the deviation of the long hand.	Refer to Fig.6, and then loosen the nut and rotate a little the screw M4 (23) to point at the zero. Fix the screw and fasten the nut.
There appears a shock during the loading of the test force or a noise of inhaling the air during the unloading	The oil volume is not sufficient in the container	Add oil according to the requirements shown in Fig.4
Great errors in the indication of the hardness value	<ol style="list-style-type: none"> 1. The indenter is broken down 2. Wrong disposition of the weights 3. The weights rub against the inner wall of the instrument due to non horizontal level of the position of the instrument 4. The protective cover is higher than the lever 5. The wrong selection of the total test force or of the indenter 	<ol style="list-style-type: none"> 1. Change the diamond or ball indenter. 2. Install the weights according to Fig.3. 3. Put the instrument in a horizontal position with a level according to the requirements in 4.2.3. 4. Lower the protective cover and let it be lower than the level of the lever, and then tighten the screw. 5. Select the test force and the indenter according to the requirements set up in Table.2.

VII Accessories (the Packing List)

Besides the main instrument, there are provided the following accessories:

NO.	Name (specifications)	Quantity
1	Rockwell Diamond Indenter	1
2	Ball Indenter ϕ 1.5875mm	1
3	Big Testing Table	1
4	Middle-sized Testing Table	1
5	“V” -shaped Testing Table	1
	Rockwell standard Blocks	
6	High & Low HRC	2 blocks in all
7	HRB Blocks	1
8	Sets of weights A、 B、 C	3 sets in all
9	Protective Plastic Corer	1
10	Instruction Manual	1 copy